

Glazing Details

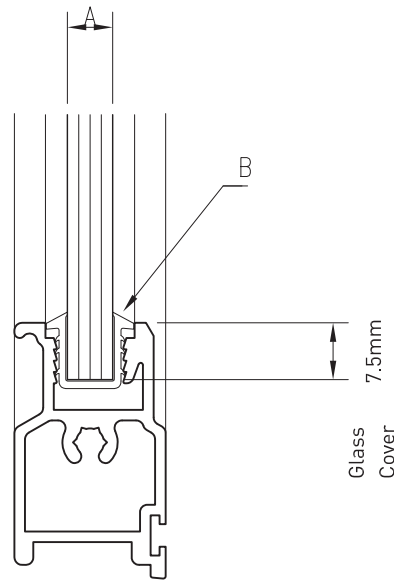

A = Glass Thickness

B = Glazing Channel

A (Glass Thickness)	B (Glazing Channel)	Material
3mm	04-513	PVC
4mm	04-514	PVC
5mm	04-515	PVC
6mm/6.38mm	04-516	PVC

Note: Maximum glass thickness = 6.38mm

Starting from the top centre of glass, assemble glazing channel around glass applying even pressure. Glazing channel will be required to be slit at all four corners, taking care not to cut all the way through. Assemble sash framework around glass and glazing channel. Check assembly for squareness, slight out of squareness may be corrected carefully knocking one corner with a rubber mallet until the assembly becomes square.

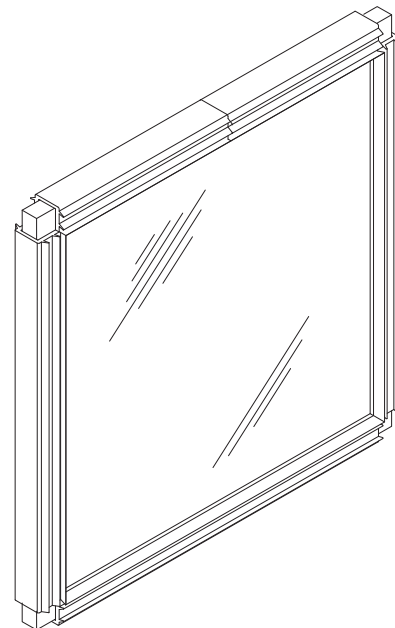

Glazing Details

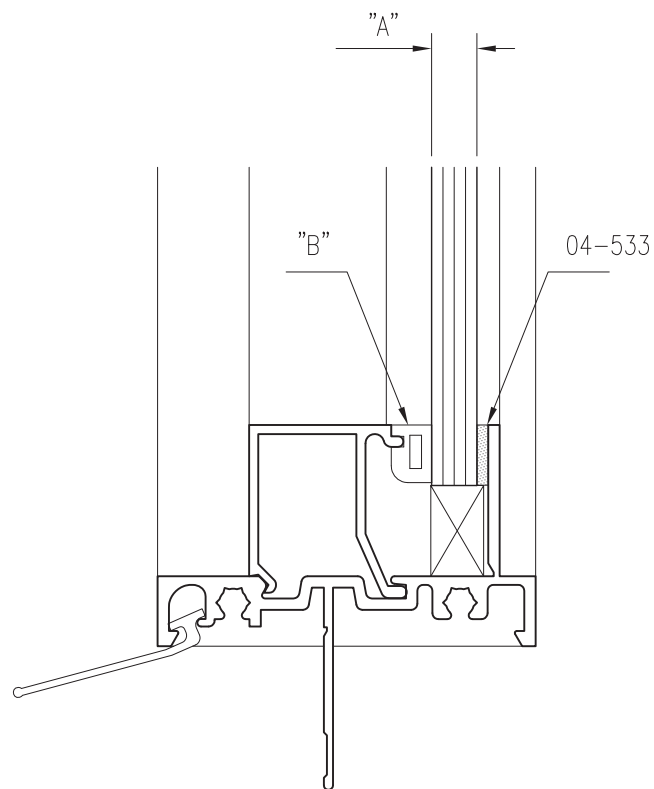

A (Glass Thickness)	B (Glazing Wedge)	Material
3mm	04-523	PVC
4mm	04-524	PVC
5mm	04-525	PVC
6mm/6.38mm	04-526	PVC

Check and ensure frame is square. Run glazing tape around the glazing leg. Position glazing blocks at 1/4 points at sill and locate glass ensuring alignment to provide equal cover on all sides. Snap in all glazing beads. Roll in wedges ensuring that corners meet.