

Glazing Details

A = Glass Thickness

B = Glazing Channel

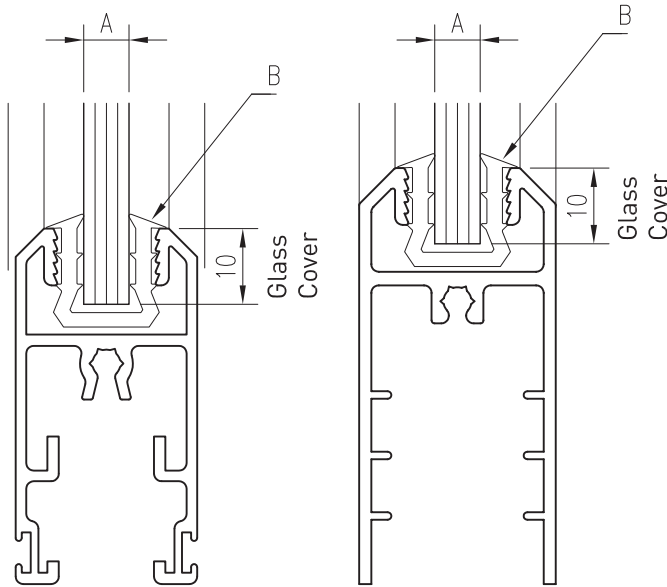

Max Glass Thickness = 10.38mm

Max Glass Thickness = 18mm

A (Glass Thickness)	B (Glazing Channel)	Material
4mm	04-545	PVC
5mm	04-067	PVC
6mm/6.38mm	04-065	PVC
8mm	04-217	PVC
10mm	04-209	PVC
18mm	04-333	PVC

Starting from the top centre of glass, assemble channel gasket around glass applying even pressure. Gasket will be required to be slit at corners, taking care not to cut all the way through. Assemble sash framework around glass and gasket. Check assembly for squareness, slight out of squareness may be corrected carefully knocking one corner with a rubber mallet until the assembly becomes square.

Note: Door rollers to be placed in position prior to assembly of door.

